

# HOBOnet® Wireless Sensor Network

## RXW Davis® Wind Speed and Direction Sensor (RXW-WCF-xxx) Manual



This sensor measures wind speed and direction and is designed to work with the HOBOnet Wireless Sensor Network in which data is transmitted wirelessly from the sensor mote across the network to the station and then uploaded to HOBOLink® web-based software. With HOBOLink, you can monitor sensor readings, view graphs, set up alarms, download data, and more.

### Specifications

Sensor	Wind Speed/Gust	Wind Direction
<b>Measurement Range</b>	0 to 76 m/sec (0 to 170 mph)	0 to 355 degrees
<b>Accuracy</b>	±1.1 m/sec (±2 mph) or ±5% of reading, whichever is greater	±7 degrees
<b>Resolution</b>	0.5 m/sec (1.1 mph)	1.4 degrees (0 to 355 degrees)
<b>Starting Threshold</b>	≤1 m/sec (2.2 mph)	1 m/sec (2.2 mph)
<b>Turning Radius</b>	108 mm (4.25 in.)	Approximately 135 mm (5.25 in.)
<b>Measurement Definition</b>	Cup revolutions are accumulated every three seconds for the duration of the logging interval (see <a href="#">Measurement Operation</a> ) <b>Wind speed:</b> Average speed for the entire logging interval <b>Gust speed:</b> The highest three-second wind recorded during the logging interval	Unit vector averaging used; vector components for each wind measurement are calculated every three seconds for duration of logging interval (see <a href="#">Measurement Operation</a> )
<b>Wireless Mote</b>		
<b>Operating Temperature Range</b>	-25° to 60°C (-13° to 140°F) with rechargeable batteries -40° to 70°C (-40° to 158°F) with lithium batteries	
<b>Radio Power</b>	12.6 mW (+11 dBm) non-adjustable	
<b>Transmission Range</b>	Reliable connection to 457.2 m (1,500 ft) line of sight at 1.8 m (6 ft) high Reliable connection to 609.6 m (2,000 ft) line of sight at 3 m (10 ft) high	
<b>Wireless Data Standard</b>	IEEE 802.15.4	
<b>Radio Operating Frequencies</b>	RXW-WCF-900: 904–924 MHz RXW-WCF-868: 866.5 MHz RXW-WCF-921: 921 MHz RXW-WCF-922: 916–924 MHz	
<b>Modulation Employed</b>	OQPSK (Offset Quadrature Phase Shift Keying)	
<b>Data Rate</b>	Up to 250 kbps, non-adjustable	
<b>Duty Cycle</b>	<1%	
<b>Maximum Number of Motes</b>	Up to 50 wireless sensors or 336 data channels per one HOBOnet RX station	
<b>Logging Rate</b>	1 minute to 18 hours	
<b>Number of Data Channels</b>	4	
<b>Battery Type/Power Source</b>	Two AA 1.2V rechargeable NiMH batteries, powered by built-in solar panel or two AA 1.5 V lithium batteries for operating conditions of -40° to 70°C (-40° to 158°F)	
<b>Battery Life</b>	With NiMH batteries: Typical 3–5 years when operated in the temperature range -20° to 40°C (-4°F to 104°F) and positioned toward the sun (see <a href="#">Deploying and Mounting</a> ), operation outside this range will reduce the battery service life With lithium batteries: 1 year, typical use	
<b>Memory</b>	16 MB	
<b>Dimensions</b>	Sensor: 470 x 191 x 121 mm (18.5 x 7.5 x 4.75 in.) Cable length: 3 m (9.8 ft) Mote: 16.2 x 8.59 x 4.14 cm (6.38 x 3.38 x 1.63 inches)	

### RXW Davis Wind Speed & Direction Sensor

#### Models:

- RXW-WCF-900 (US)
- RXW-WCF-868 (Europe)
- RXW-WCF-921 (Taiwan)
- RXW-WCF-922 (Australia/NZ)

#### Included Items:

- Cable ties
- Screws

#### Required Items:

- Weather-resistant cable ties or cable clips
- Electrical tape
- Handheld compass, local area map, or handheld GPS

#### If mounting on tripod or mast:

- Adjustable wrench

#### If mounting on wooden surface:

- Drill with 5 mm (3/16 inch) drill bit

#### Accessories:

- Grounding kit (M-GKA)

## Specifications (continued)

<b>Weight</b>	Sensor and cable: 1.332 kg (2 lb, 15 oz) Mote: 223 g (7.87 oz)
<b>Materials</b>	Sensor: Polycarbonate wind cups, sealed stainless steel bearing, UV-resistant ABS wind vane and black-anodized aluminum anemometer arm Mote: PCPBT, silicone rubber seal
<b>Environmental Rating</b>	Sensor: Weatherproof Mote: IP67, NEMA 6
<b>Compliance Marks</b>	<p><b>FC</b> RXW-WCF-900: See the last page.</p> <p><b>CE</b> RXW-WCF-868: The CE Marking identifies this product as complying with all relevant directives in the European Union (EU).</p> <p><b>CCC</b> RXW-WCF-921: See the last page.</p> <p><b>RoHS</b> RXW-WCF-922: See the last page.</p>

## Mote Components and Operation

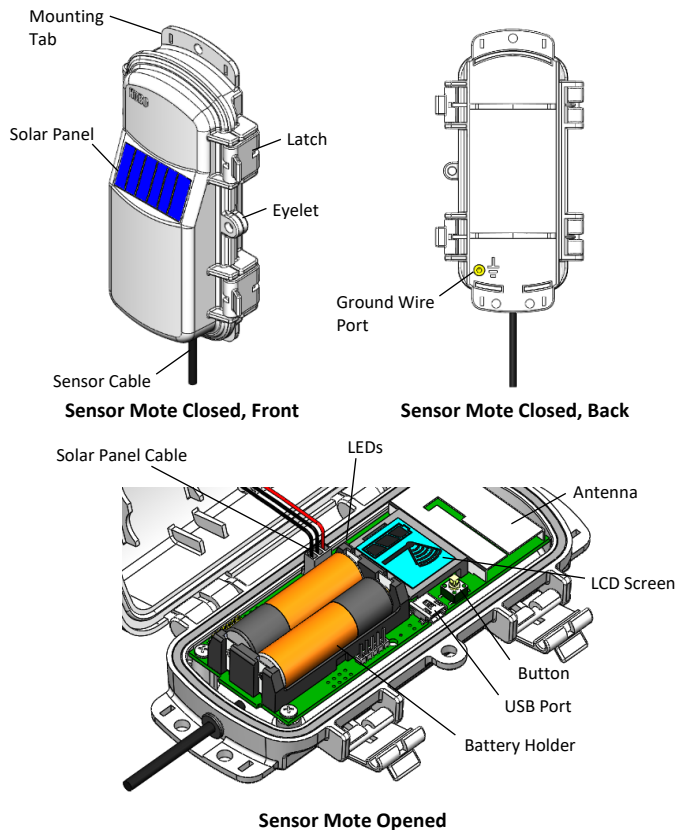

**LEDs:** There are two LEDs to the left of the LCD screen. The green LED blinks while the mote is joining a network, blinking quickly while the mote searches for a network and then slowly as the mote registers with the network. Once the network registration process is complete, the blue LED blinks every 4 seconds to indicate normal operation. If the mote is not currently part of a network, the blue LED is off. If the blue LED is on and not blinking, there is a problem with the mote. Contact Onset Technical Support.

**Solar Panel Cable:** Connects the built-in solar panel to the mote circuitry.

**Battery Holder:** Holds the batteries as shown (see [Battery Information](#)).

**USB Port:** Connects the mote to a computer via USB cable if you need to update the firmware (see [Updating Mote Firmware](#)).

**Button:** Push this button for 1 second to illuminate the LCD or 3 seconds for the mote to search for an HOBOnet Wireless Sensor Network to join (see [Adding the Mote to the HOBOnet Wireless Sensor Network](#)).

**LCD Screen:** The mote is equipped with an LCD screen that displays details about the current status. The following example shows all symbols illuminated on the LCD screen followed by definitions of each symbol in the table.



LCD Symbol	Description
	The battery indicator shows the approximate battery charge remaining.
	Signal strength indicator. The more bars, the stronger the signal between motes. If there is no X icon next to the signal strength indicator, the mote is part of a HOBOnet Wireless Sensor Network.
	An empty signal strength indicator plus the X icon indicates that the mote is not currently part of a network. See <a href="#">Adding the Mote to the HOBOnet Wireless Sensor Network</a> for details on how to add a mote to the network.

**Mounting Tab:** Use the tabs at the top and bottom of the mote to mount it (see [Deploying and Mounting](#)).

**Solar Panel:** Position the solar panel towards the sun to charge the mote batteries (see [Deploying and Mounting](#)).

**Sensor Cable:** Connects the mote to the sensor.

**Eyelet:** Attach a 3/16 inch padlock to the eyelet for mote security.

**Latch:** Use the two latches to open and close the mote door.

**Ground Wire Port:** Use this port to connect a ground wire (see [Deploying and Mounting](#)).

**Antenna:** A built-in antenna for the radio communications across the HOBOnet Wireless Sensor Network.

LCD Symbol	Description
	When the mote is in the process of joining a network, the signal strength icon blinks and the bars in the icon cycle from left to right. The X icon blinks during the last step in the network registration process (see <a href="#">Adding the Mote to the HOBOnet Wireless Sensor Network</a> for details).

### Sensor Components

The sensor includes the following components.

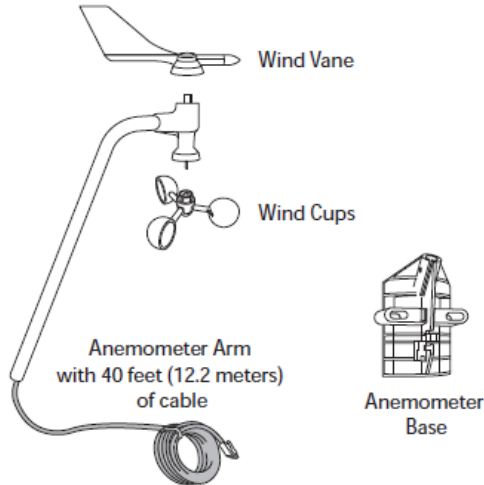

The sensor also includes a hardware kit with the items most commonly needed for installation as shown below. The items you use from the kit depend on where you install the sensor. You may need to adapt or purchase additional hardware to suit your individual requirements.

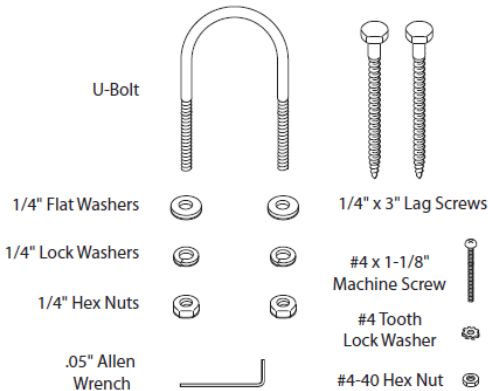

### Adding the Mote to the HOBOnet Wireless Sensor Network

The mote must join a HOBOnet Wireless Sensor Network before it can begin measuring wind speed and direction and transmitting data. This requires accessing the station and the mote at the same time so we recommend that you complete these steps before deploying the mote.

**Important:** If you are setting up a new station, follow the instructions in the station quick start before setting up this mote: [HOBOnet MicroRX Station for HOBOnet \(RX2105 and RX2106\) Quick Start Guide](#) or [HOBOnet RX3000 Remote Monitoring Station Quick Start Guide](#).

To add a mote to the network:

1. If the LCD is blank on the station, press any button to wake it up.
2. Press the Select button once (which shows the number of smart sensors installed) and then press it again to switch to the module with the manager (module 2 on RX2105 or RX2106 stations).

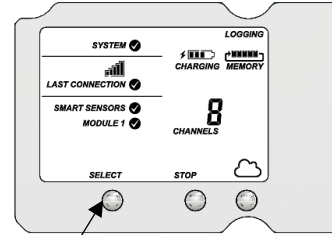

Press this button to view the module.

3. Press the Search button (the magnifying glass). The magnifying glass icon blinks while the station is in search mode.

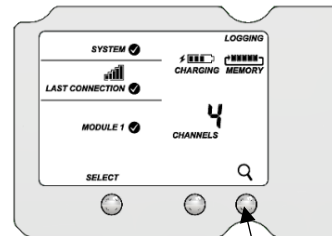

Press this button so the station is ready to have motes join the network.

4. Open the mote door and install the batteries if you have not already done so.
5. Press the button on the mote for 3 seconds. The signal strength icon flashes and then cycle.

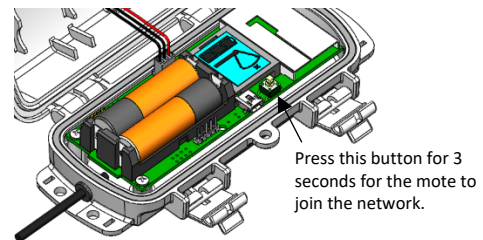

6. Watch the LCD on the mote.

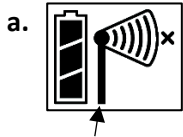

This signal strength icon blinks while searching for a network.

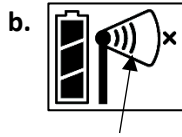

Once a network is found, the icon stops flashing and the bars cycle from left to right.



This network connection X icon blinks while the mote completes the registration process, which may take up to five minutes.



Once the mote has finished joining the network, the X icon disappears and the channel count on the station LCD increases by four (three for wind speed, direction, and gust speed, and one for the mote battery).

The green LED blinks quickly while the mote searches for a network to join and then blinks slowly while it completes the network registration. Once the mote has finished joining the network, the green LED turns off and the blue LED then blinks indefinitely while the mote is part of the network.

**Note:** If the mote cannot find the network or has trouble remaining connected during this process, make sure the mote is in a vertical, upright position and within range of the station.

7. Press the Search button (the magnifying glass) on the station to stop searching for motes.

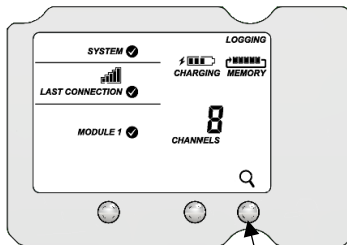

Press this button again to stop searching for motes.

If you added more than one more mote to the network, then the total channel count on the station LCD for the manager module represents all measurement channels plus a battery channel for each mote in the HOBONet Wireless Sensor Network.

Sensor measurements are recorded at the logging interval specified in HOBOLink, transmitted to the station, and uploaded to HOBOLink at the next connection interval. Use HOBOLink to monitor mote status and health. If a mote is temporarily offline, any logged data is saved until it is back online. In addition, if a mote is offline for 30 minutes, the station automatically connects to HOBOLink and reports the mote as missing. Once the mote is back online, it uploads any logged data the next time the station connects to HOBOLink.

See the [HOBOLink Online Help](#) for details on how to change the logging and connection intervals, view data, check mote status, add the mote to a map, and more.

## Assembling the Sensor

### Attaching the Wind Vane

The wind direction has been calibrated in the factory so that the wind direction is correct when the arm is installed pointing north and the vane is installed correctly.

1. Slide the wind vane onto the wind vane shaft. The shaft's cross-section is D-shaped to ensure that the anemometer is installed correctly.
2. Tighten the set screw in the wind vane with the Allen wrench.

### Attaching the Wind Cups

1. Push the wind cups onto the anemometer's stainless steel wind cup shaft.
2. Slide the wind cups up the shaft as far as possible.

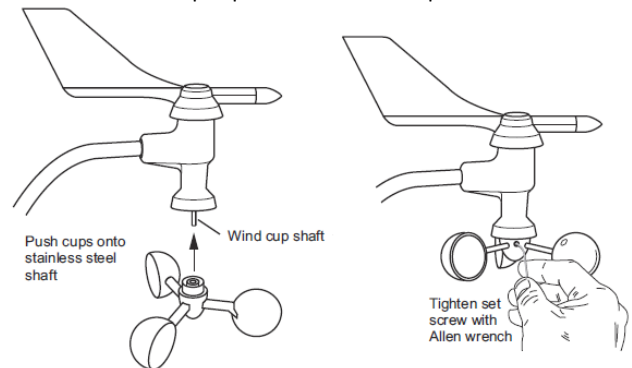

3. Use the Allen wrench provided to tighten the set screw on the side of the wind cups. The wind cups should drop slightly when you let go.
4. Ensure the set screw is screwed in fully and very tightly. Failure to do so causes the anemometer to function improperly.
5. Spin the wind cups; they should spin freely. If they do not spin freely, take them off and repeat these steps

### Attaching the Anemometer Arm to the Base

1. Insert the anemometer arm into the base, sliding the cable through the notch in the base as shown below. Be sure to line up the small hole in the arm with the holes in the base.

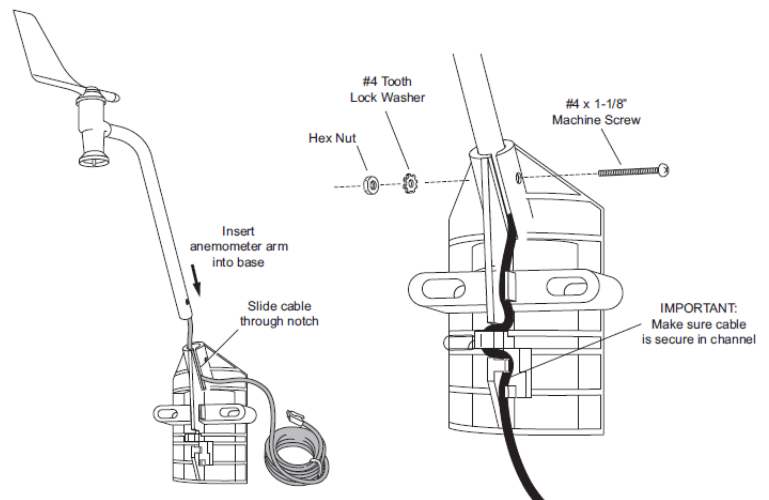

2. Insert the machine screw through the holes in the base and arm.
3. Slide the tooth-lock washer and hex nut onto the machine screw. Tighten the hex nut while holding the screw with a Phillips head screwdriver to prevent it from turning.
4. Press the sensor cable firmly and completely into the zig-zagging channel in the base, starting from the arm and progressing downward to the bottom of the base.

## Deploying and Mounting

### Mounting and Positioning the Mote

- Mount the mote to a mast or pipe using cable ties or affix the mote to a wooden post or flat surface with screws. Insert the cable ties or screws through the holes on the mounting tabs.
- Consider using plastic poles such as PVC to mount the mote as certain types of metal could decrease signal strength.
- Make sure the mote remains in a vertical position once it is placed in its deployment location for optimal network communications.
- Make sure the mote door is closed, with both latches fully locked to ensure a watertight seal.
- Consider using a 3/16 inch padlock to restrict access to the mote. With the mote door closed, hook a padlock through the eyelet on the right side of the door and lock it.
- Position the mote towards the sun, making sure the solar panel is oriented so that it receives optimal sunlight throughout each season. It may be necessary to periodically adjust the mote position as the path of the sunlight changes throughout the year or if tree and leaf growth alters the amount of sunlight reaching the solar panel.
- Make sure the mote is mounted a minimum of 1.8 m (6 ft) from the ground or vegetation to help maximize distance and signal strength.
- Place the mote so there is full line of sight with the next mote. If there is an obstruction between two sensor motes or between the sensor mote and the manager, use a repeater mounted on the obstruction. For example, if there is a hill between the sensor mote and the manager, place a repeater at the top of the hill between the sensor mote and the manager.
- There should not be more than five motes in any direction at their maximum transmission range from the manager. Data logged by a wireless sensor must travel or “hop” across the wireless network from one mote to the next until it ultimately reaches the manager connected to the station. To make sure the data can successfully travel across the network, the mote should not be more than five hops away from the manager.
- The HOBONet Wireless Sensor Network can support up to 50 wireless sensors or 336 data channels per one HOBONet RX station.
- Use a #4-40 screw to attach a ground wire to the port on the back of the mote if you are deploying the mote in a location where lightning is a concern.

### Sensor Mounting Guidelines

Use the following guidelines to determine the best location for installing the sensor.

- To ensure correct orientation of the wind vane, mount the sensor so that the anemometer arm points north. See [North Alignment](#) for steps on finding true north.
- For the most accurate readings, mount the sensor 2 m (7 ft) or more above the ground and consistent with meteorological standards for the application. Mount the sensor at least 2.1 m (7 ft) above the roof line if you are mounting it on a roof and mount it at a distance of at least five times the height of the nearest tree, building, or other obstruction. You may do this by mounting the sensor on an Onset tripod or mast or a metal pipe. You may mount the sensor on a wooden post if it has a side facing due north for mounting.
- The tripod or mounting mast must be properly grounded. For field installations, use Onset’s Grounding Kit (M-GKA).
- If you live in an area subject to frequent thunderstorms, installing a lightning rod nearby can reduce the risk of damage.
- Be sure to secure the sensor cable with cable ties to protect it from damage.
- Secure the mast the wind sensor is mounted on so that it does not vibrate. If you are using Onset masts or tripods, secure them with guy wires.
- The sensor can be damaged with improper handling. Store the sensor in its shipping box until you are ready to install it.
- To minimize measurement errors due to ambient RF, use the shortest possible probe cable length and keep the probe cable as far as possible from other cables carrying high frequency or high current signals.

### Mounting the Sensor on a Mast

Follow these instructions for mounting the sensor on a tripod or mast. Use the included U-bolts to mount the sensor on a mast or tripod with an outside diameter ranging from 32–44 mm (1.25–1.75 inches). Use larger U-bolts (not supplied) to mount it on a mast or tripod with a maximum outside diameter of 64 mm (2.5 inches). To mount the sensor on a mast or tripod smaller than 32 mm (1.25 inches), use a U-Bolt that fits the anemometer base openings, but has a shorter threaded section.

1. Place the U-bolt around the pole so that its two ends extend through the holes in the mounting base. Loosely secure them with the flat washers, lock washers, and hex nuts.

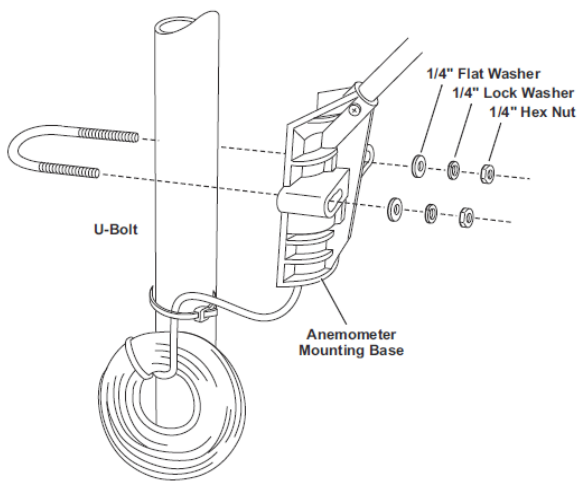

2. Raise the anemometer to the desired height on the pole and swivel it so the anemometer arm is pointing north.
3. Using an adjustable wrench or 7/16 inch wrench, tighten the hex nuts until the anemometer is firmly fastened on the pole.

### Mounting the Sensor on a Wooden Post or Surface

Follow these instructions for mounting the sensor on a wooden post or surface. The sensor must be mounted on the side that is facing due north (the mounting arm must point north for proper wind direction measurements).

1. Hold the anemometer base against the wood's surface and use a pencil to mark the location of the two holes on the base.
2. Use a drill with a 5 mm (3/16 inch) drill bit to make pilot holes in these locations.
3. Drive the 3-inch lag screws through the holes in the anemometer base and into the wood.

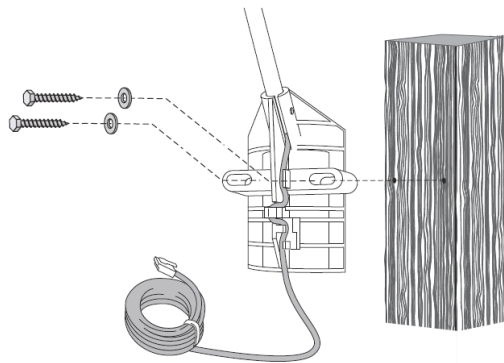

### Securing the Sensor Cables

To prevent fraying or cutting the anemometer cables where it is exposed to weather, secure it so it does not whip about in the wind. Use cable clips or weather resistant cable ties to secure the cable. Place clips or cable ties approximately every 1 to 1.6 m (3 to 5 ft). Do not use metal staples to secure cables as they can cut the cables.

### Measurement Operation

Wind speed measurements are averaged automatically every 3 seconds within each logging interval. Wind speed is reported as the average speed for the entire logging interval. For example,

if the logging interval is set to 1 minute, 20 measurements (1 measurement every 3 seconds for 60 seconds) are averaged together and the result is logged each minute. The gust speed is the highest 3-second wind recorded during the logging interval.

Unit vector averaging is used to determine wind direction because traditional averaging would produce inaccurate results. For example, three measurements of 350, 11, and 12 degrees—which are all winds from the north—averaged together would result in 126 degrees, which incorrectly indicates a southeasterly wind. Instead, the vector components (North/South and East/West) for each wind measurement are calculated every three seconds for the duration of the logging interval. At the conclusion of the logging interval, the North/South and East/West components are averaged and then re-combined to calculate the average wind direction for the logging interval.

### North Alignment

The sensor must be oriented to true north to obtain meaningful data. There are two methods to align the sensor:

- Compass Alignment
- Global Positioning Satellite (GPS) alignment

**Note:** You must know the magnetic declination to align the direction sensor to true north using a magnetic compass. Worldwide declination information is available from the National Space Science Data Center at:

<https://www.ngdc.noaa.gov/geomag/declination.shtml>

### Compass Alignment

Tools required:

- Compass
- Binoculars
- Tape (such as electrical, packing, or duct tape)

This procedure requires two people.

1. Position the wind vane so that it points in the same direction as the mounting arm. Secure the vane on the arm with a piece of tape so that the vane cannot rotate.
2. While standing 150 to 200 feet south of the sensor, use the compass to determine magnetic north. If true north is the same as magnetic north, align yourself so the compass points north and directly at the sensor. If you are in area with an east variation, align yourself so that the station is that number of degrees to the east of magnetic north. If you are in an area with a west variation, align yourself so that the station is that number of degrees to the west of magnetic north.
3. While viewing the sensor through binoculars, instruct another person to rotate the arm to point the vane north. The vane should seem to disappear from sight when properly aligned.
4. Once you've obtained the correct position, secure the sensor base and remove the tape.

### GPS Alignment

Tools required:

- Handheld GPS with WAAS-enabled receiver or any similar high accuracy GPS device
- Flag, orange cone, or other temporary marker

- Access to your HOBOLink account

This procedure requires only one person, but is easier to complete with two people. In this procedure, you will be using the GPS receiver first to create an arbitrary waypoint and then to determine the bearing from the sensor to that waypoint. You will then align the sensor so that when the vane is pointed at the waypoint, the direction reported by HOBOLink matches the GPS receiver's bearing to the waypoint.

1. In HOBOLink, temporarily set the logging interval to 1 minute or the fastest logging interval supported by the device communication plan (if applicable). Refer to the online help for details on operating HOBOLink.
2. Pick a visible location that is at least 100 meters (110 yards) away from the sensor and walk to it. Establish a waypoint with the handheld GPS receiver. You may want to use averaging to minimize the waypoint position error if your GPS receiver is so equipped. (For best results, the estimated position error of the waypoint should be less than 10 feet if the distance to the sensor is 100 meters, and less than 20 feet for a distance of 200 meters. Mark the waypoint with a flag, orange cone, or other suitable marker. Walk back to the sensor and determine the bearing to the waypoint you just created with the GPS receiver. Again you may need to determine the average value of the bearing to keep the errors to a minimum.
3. Check the latest reading in HOBOLink keeping in mind that the data is only updated when the station connects to HOBOLink. It may take a couple of connections before the latest reading from the mote is transmitted to the station and then uploaded to HOBOLink. The value should match the angle obtained with the GPS receiver. If it does not, reposition the sensor vane so that it points directly at the waypoint flag or marker and then rotate the sensor mounting arm as needed and wait for the next HOBOLink reading. Repeat this until the wind direction sensor value in HOBOLink matches the angle obtained with the GPS receiver.
4. Once the vane is in position, secure the mounting base and then double-check that the reported angle is correct.

## Maintenance

The sensor does not normally require any maintenance other than an occasional cleaning. If the vane becomes dirty, rinse it with mild soap and fresh water. Do not immerse the sensor in water or use any organic solvents to clean the unit. Do not attempt to lubricate the wind cup shaft or bearings or the wind vane shaft. Natural or synthetic lubricants inhibit the normal operation of the anemometer.

The mote is designed for outdoor use, but should be inspected periodically. When inspecting the mote, do the following:

- Verify the mote is free of visible damage or cracks.
- Make sure the mote is clean. Wipe off any dust or grime with a damp cloth.
- Wipe off any water before opening the mote.
- Make sure the interior seal is intact and the latches are fully locked when the mote door is closed.

## Verifying Sensor Accuracy

We recommend that you check the accuracy of the sensor annually. The sensor cannot be calibrated. If the sensor is not providing accurate data, then it is damaged or possibly worn out if it has been in use for several years.

## Updating Mote Firmware

If you have trouble with your mote, contact Onset Technical Support who will provide an update file, if you need one. To install that file:

1. Connect the mote to the computer with a USB cable (open the mote door and use the USB port to the right of the LCD). The blue LED is illuminated while connected.
2. The mote appears as a new storage device in the computer's file storage manager. Copy the downloaded firmware file to the new storage device (the mote). The blue LED blinks slowly while the file is copying.
3. After the file is copied to the mote, the LED stops blinking and remains a steady blue. Eject the storage device from the computer and disconnect the cable from the mote. The firmware installation process begins automatically on the mote. The blue LED blinks rapidly while the firmware is installed. Once the firmware installation is complete, the LCD symbols return and the mote automatically rejoins the network.

### Notes:

- Mac® users: A message may appear indicating the disk has not ejected properly when disconnecting the mote from the computer. The mote is operational and you can ignore the message.
- If the blue LED turns off abruptly while copying the file or installing the firmware, a problem has occurred. Contact Onset Technical Support for help.

## Battery Information

The mote uses two 1.2 V rechargeable NiMH batteries (HRB-NiMH-2), charged by the built-in solar panel. The quality and quantity of solar light can affect whether the battery is sufficiently charged to last through the night and cloudy periods. Make sure the mote is placed in a location that receives several hours of sunlight each day. If the mote does not receive enough sunlight to recharge the batteries, the battery life is estimated at 3–4 months. When batteries are regularly recharged, expected battery life is estimated at 3–5 years. Battery life varies based on the ambient temperature where the mote is deployed, the logging interval, the number of tripped alarms, and other factors. Deployments in extremely cold or hot temperatures can impact battery life. Estimates are not guaranteed due to uncertainties in initial battery conditions and operating environment.

Mote operation stops when battery voltage drops to 1.8 V. Mote operation returns if the battery recharges to 2.3 V. If the batteries are unable to be recharged, replace them with fresh rechargeable batteries. **Note:** If you install used rechargeable batteries that together are less than 2.3 V, the mote will not resume operation.

To replace rechargeable batteries:

1. Open the mote door.

2. Remove the old batteries and install fresh ones observing polarity.
3. Make sure the solar panel cable is plugged in.

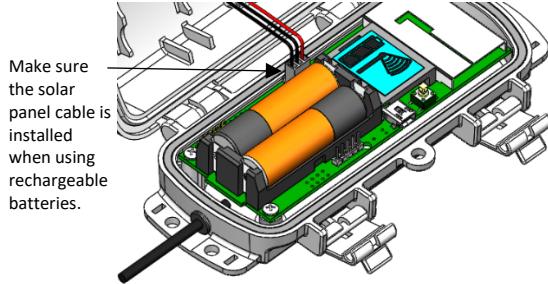

The mote contacts the network once the new batteries are installed. The green LED blinks quickly while the mote searches for a network to join and then blinks slowly while it completes the network registration. Once the mote has finished joining the network, the green LED turns off and the blue LED then blinks indefinitely while the mote is part of the network.

### **Lithium Batteries**

You can use two 1.5 V lithium batteries (HWSB-LI) for operation at the extreme ends of the mote operating range. Lithium battery life is estimated at 1 year, but varies based on the ambient temperature where the mote is deployed, the logging interval, the number of tripped alarms, and other factors. Estimates are not guaranteed due to uncertainties in initial battery conditions and operating environment. When using lithium batteries, you must disconnect the solar panel cable because the batteries do not recharge.

To install lithium batteries:

1. Open the mote door.
2. Remove any old batteries and install the new ones observing polarity.
3. Push in the side tab of the solar panel cable connector and pull the connector out of the cable port.
4. Place the connector in the slot on the inside of the mote door. Make sure the solar panel cables are tucked inside the door so that they do not interfere with the interior seal when the mote is closed.

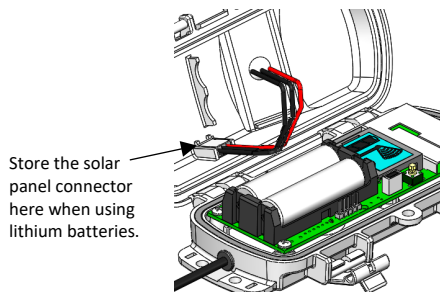

The mote contacts the network once the new batteries are installed. The green LED blinks quickly while the mote searches for a network to join and then blinks slowly while it completes the network registration. Once the mote has finished joining

the network, the green LED turns off and the blue LED then blinks indefinitely while the mote is part of the network.

**⚠ WARNING:** Do not cut open, incinerate, heat above 85°C (185°F), or recharge the lithium batteries. The batteries may explode if the mote is exposed to extreme heat or conditions that could damage or destroy the battery cases. Do not mix battery types, either by chemistry or age; batteries may rupture or explode. Do not dispose of the logger or batteries in fire. Do not expose the contents of the batteries to water. Dispose of the batteries according to local regulations for lithium batteries.

---

### Federal Communication Commission Interference Statement

This equipment has been tested and found to comply with the limits for a Class B digital device, pursuant to Part 15 of the FCC Rules. These limits are designed to provide reasonable protection against harmful interference in a residential installation. This equipment generates uses and can radiate radio frequency energy and, if not installed and used in accordance with the instructions, may cause harmful interference to radio communications. However, there is no guarantee that interference will not occur in a particular installation. If this equipment does cause harmful interference to radio or television reception, which can be determined by turning the equipment off and on, the user is encouraged to try to correct the interference by one of the following measures:

- Reorient or relocate the receiving antenna
- Increase the separation between the equipment and receiver
- Connect the equipment into an outlet on a circuit different from that to which the receiver is connected
- Consult the dealer or an experienced radio/TV technician for help

This device complies with Part 15 of the FCC Rules. Operation is subject to the following two conditions: (1) This device may not cause harmful interference, and (2) this device must accept any interference received, including interference that may cause undesired operation.

**FCC Caution:** Any changes or modifications not expressly approved by the party responsible for compliance could void the user's authority to operate this equipment.

### Industry Canada Statements

This device complies with Industry Canada license-exempt RSS standard(s). Operation is subject to the following two conditions: (1) this device may not cause interference, and (2) this device must accept any interference, including interference that may cause undesired operation of the device.

### Avis de conformité pour l'Industrie Canada

Le présent appareil est conforme aux CNR d'Industrie Canada applicables aux appareils radio exempts de licence. L'exploitation est autorisée aux deux conditions suivantes : (1) l'appareil ne doit pas produire de brouillage, et (2) l'appareil doit accepter tout brouillage radioélectrique subi, même si le brouillage est susceptible d'en compromettre le fonctionnement.

To comply with FCC and Industry Canada RF radiation exposure limits for general population, the logger must be installed to provide a separation distance of at least 20cm from all persons and must not be co-located or operating in conjunction with any other antenna or transmitter.

### NCC Statement

經型式認證合格之低功率射頻電機，非經許可，公司、商號或使用者均不得擅自變更頻率、加大功率或變更原設計之特性及功能。

低功率射頻電機之使用不得影響飛航安全及干擾合法通信；經發現有干擾現象時，應立即停用，並改善至無干擾時方得繼續使用。前項合法通信，指依電信法規定作業之無線電通信。低功率射頻電機須忍受合法通信或工業、科學及醫療用電波輻射性電機設備之干擾。

### Translation:

#### Article 12

Without permission granted by the NCC, any company, enterprise, or user is not allowed to change frequency, enhance transmitting power or alter original characteristic as well as performance to an approved low power radio-frequency device.

#### Article 14

The low power radio-frequency devices shall not influence aircraft security and interfere with legal communications. If found, the user shall cease operating immediately until no interference is achieved. The said legal communications means radio communications is operated in compliance with the Telecommunications Act. The low power radio-frequency devices must be susceptible with the interference from legal communications or ISM radio wave radiated devices.