

Using the pHionics STs pH Sensor with a HOBO® RX3000 Station

This application note describes how to connect, calibrate, and operate the pHionics STs pH sensor with the HOBO RX3000 station. The pH sensor is compatible with any RX3000 configuration (cellular, Ethernet, or Wi-Fi) that is equipped with the optional four-channel analog input module (RXMOD-A1). We suggest you use a 6-watt solar panel to ensure that the battery maintains a proper charge.

Portions of the pHionics Technical Manual are used within this application note. The full manual is available at http://www.phionics.com/130216_phionics_006.htm#pdf_downloads. Read and understand the full manual before attempting to use this device with the RX3000 station. Send questions regarding the specific application, accuracy, or use of the pHionics sensor to pHionics directly at <http://www.phionics.com/> or contact@phionics.com.

More information on configuring the RX3000 station with HOBOLink is available in the [HOBOLink Online Help](#). More information on the RX3000 station hardware is available in the [HOBO RX3000 Remote Monitoring Station User's Manual](#).

To ensure the best accuracy for your application and to confirm proper operation of the transmitter, we recommend periodic recalibration. The frequency of the recalibration is best determined empirically for each application. To discuss your application to determine the best calibration frequency, contact pHionics directly at <http://www.phionics.com/>.

Specifications:

Series STs Channel 1, pH transmitter

pH sensing range	0-14 pH, custom ranges available
Output Current	4 to 20 ma, true 2-wire
Power supply voltage	7 to 36 vdc
Isolation	600 vdc, >70 db at 50/60 hz
Linearity	± 0.004 pH
Accuracy	± 0.014 pH (after calibration)
Sensitivity	± 0.01 pH
Stability	± 0.03 pH
Repeatability	± 0.01 pH
Electrode type	glass, Teflon double junction
Response time (including electrodes)	95% < 5 seconds
Temperature compensation	automatic, 0-50 °C
Pressure	0-100 psi
Humidity	0-100%
Wetted materials	316 ss, PVDF or Delrin, Viton, glass, titanium optional
Length	362 mm (14.25 in.)
Diameter	19 mm (0.750 in.) maximum
Weight (excluding cable)	< 0.22 kg (0.5 lb.)
Cable type	Removable, shielded polyurethane, water-blocked, Kevlar reinforced,
	1.36 kg/100 feet
Cable length (standard)	7.6 meters (25 feet)
Cable from transmitter to power supply	4 conductor, twisted pair, 3 mile maximum
pH channel wire colors	Red (+), Black (-)

Channel 2, temperature transmitter

Range	0-50 °C
Output Current	4 to 20 ma, true 2-wire
Linearity	± 0.5 °C
Accuracy	± 1 °C
Power supply voltage	7 to 36 vdc
Isolation	600 vdc, >70 db at 50/60 hz
Cable from transmitter to power supply	4 conductor, twisted pair, 3 mile maximum
Temperature channel wire colors	White (+), Green (-)

Viton, Teflon, Kevlar, Delrin, and Kynar are registered trademarks of the DuPont company

phionics inc

© 2013 phionics Inc. All rights reserved.
www.phionics.com

www.pHionics.com

pHionics™, pH-Kit™, and sensorloger™ are trademarks of pHionics Inc.. The pHConn™ connector system and the pH-Kit™ are trademarks of pHionics Inc.. Patent Nos. 6,331,117, 6,612,816, 6,824,384, 6,834,560, 6,993,996, and 7,263,716. Copyright pHionics 2013.



Insertion (in-line)
typical applicaton
shown with
anti-blow-out
316 SS compression fitting
(P/N cmp34s/ab)

cmp34s/ab

Mounting

1-1/2 inch PVC
or equivalent

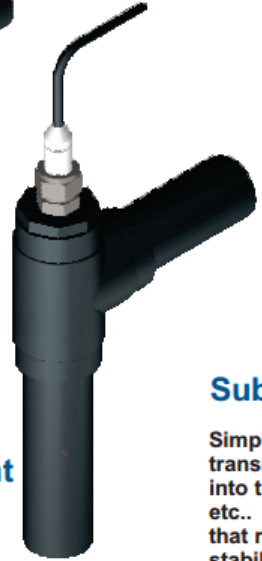

Submersion

Simply lower the transmitter and cable into the tank, lake, well, etc.. For applications that require more stability and/or protection of the cable and transmitter from mixers, chemical injection points, etc. -- reverse the cmp34s compression fitting and mount at the end of a standpipe or equivalent, as shown. (Conductivity transmitter shown in example at right)



Voice: 1-775-339-0565, Fax: send PDF to pdf@pHionics.com, e-mail: contact@pHionics.com, Web: www.pHionics.com

Wiring to the RX3000 Analog Sensor Module (RXMOD-A1)

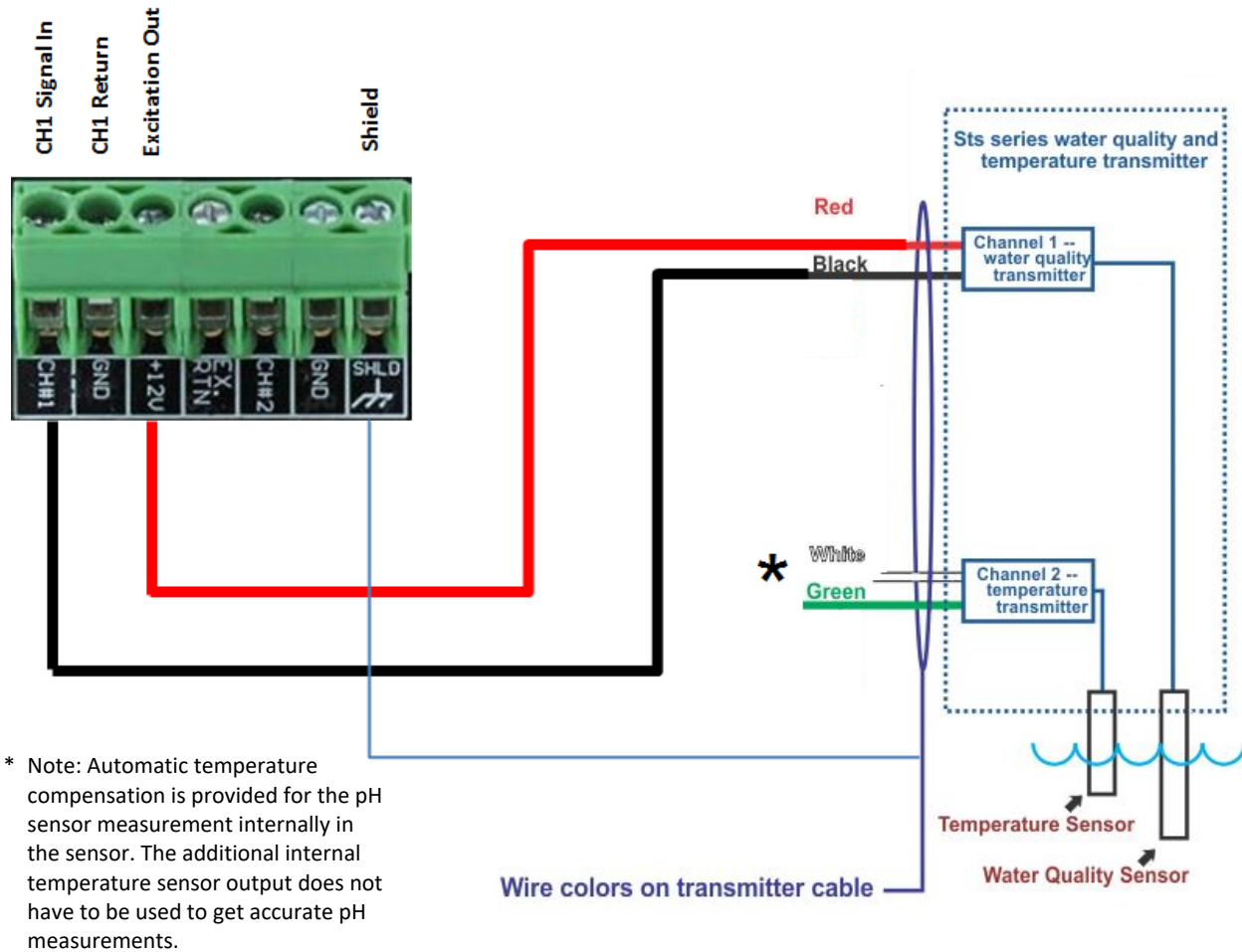

Calibrating the Sensor using the RX3000 Station and HOBOLink

Important: For the instructions in this section, be sure to follow safe laboratory procedures when handling pH buffers. We suggest using rubber gloves and eye protection.

1. Immerse the pH sensor in a liquid of a known (for example, a pH 4.01 buffer), stable pH value that measures close to the bottom of the range to be monitored.
2. In HOBOLink, select Devices then click the wrench icon on your station's tile.
3. Select Analog Sensors Logging.
4. Set the Logging Interval to 1 minute, and select Use Excitation Power. Select Warmup and enter 3 seconds.
5. Scroll down to Sensor Configuration and select Enable channel. Enter a label if you want one.
6. Select RAW-C-20 from the Sensor Type/Input dropdown. Click Save.
7. Allow the sensor to stabilize (a minimum of 5 minutes).
8. Initiate a call to HOBOLink by pressing the Connect button below the cloud icon on the RX3000 station.
Note: If the station is not currently logging, press the Start button instead of the Connect button to begin logging data.

-
9. Take note of the mA value reported on the device page in HOBOLink.
 10. Immerse the sensor in liquid of a second known pH value (for example a pH 7.00 buffer).
 11. After it stabilizes, initiate another call to HOBOLink by pressing the Connect button below the cloud icon on the station. Take note of the reported Scaled Units value on the device page in HOBOLink as you did earlier.
 12. Select Enable Scaling and enter the two Scaled Units values as your two Real Low and Real High values and the known concentrations as the Scaled Low and Scaled High values. Enter pHionics as the Scaled Measurement Type. Click Save.
 13. Initiate another call to HOBOLink or wait until the next scheduled connection for the changes to take effect.