

T-WNB-3D-480

WattNode 480 VAC 3-phase Delta/Wye kWh Transducer Sensor



For sub-metering, net-metering, energy management, and performance contracting applications, the WattNode 480 VAC 3-phase Delta/Wye kWh Transducer Sensor works with Magnelab AC Current Transformers and a Pulse Input Adapter to provide True RMS kilowatt hours of energy used, even for loads with non-sinusoidal waveforms.

Supported Measurements

Kilowatt Hours (kWh)

Features

- Measures 1, 2, or 3 phases in 2, 3, or 4 wire configurations
- Use with wide choice of CTs (sold separately); ratings from 5 to 1500 amps
- Accurate measurement of 1-, 2-, or 3-phase configurations
- Easy to install and wire
- Pulse output: compatible with pulse input logger models
- Small size: can be installed in existing service panels or junction boxes
- Diagnostic LEDs: confirms proper installation for all phases
- Bidirectional metering: net metering for PV (photovoltaic) solar and wind power generation with only one meter
- Metering of variable frequency drives
- Line powered: no external supply required
- Detachable terminal blocks: easy to install and remove.
- UL, cUL listed: designed and tested for safety and use throughout North America
- CE Mark: can be installed throughout the EU

Contact Us

Sales (8am to 5pm ET, Monday through Friday)

- Email sales@onsetcomp.com
- Call 1-508-759-9500
- In U.S. toll free 1-800-564-4377
- Fax 1-508-759-9100

Onset Computer Corporation
470 MacArthur Boulevard
Bourne, MA 02532

Technical Support (8am to 5pm ET, Monday through Friday)

- Contact Product Support www.onsetcomp.com/support/contact
- Call 1-508-759-9500
- In U.S. toll free 1-877-564-4377

WattNode 480 VAC 3-phase Delta/Wye kWh Transducer Sensor (T-WNB-3D-480) Specifications

Operating: voltage range: $\pm 20\%$ of nominal

Frequency: 60 Hz

CT input: 0-0.5 VAC operating, 3 VAC maximum

Connectors: UL, CSA recognized, detachable screw terminals (14 AWG), 600V

Operating temp range: -30 to 60°C (-22 to 140°F)

Operating humidity range: 0 to 90% RH, non-condensing

Dimensions: 8.5 cm x 14.3 cm x 3.8 cm (3.3 in. x 5.6 in. x 1.5 in.)

Weight: 295 g (10.4 oz.)

Number of data channels: 2

To download the manual from Continental Control Systems LLC click [here](#).

Below is a diagram of a typical installation

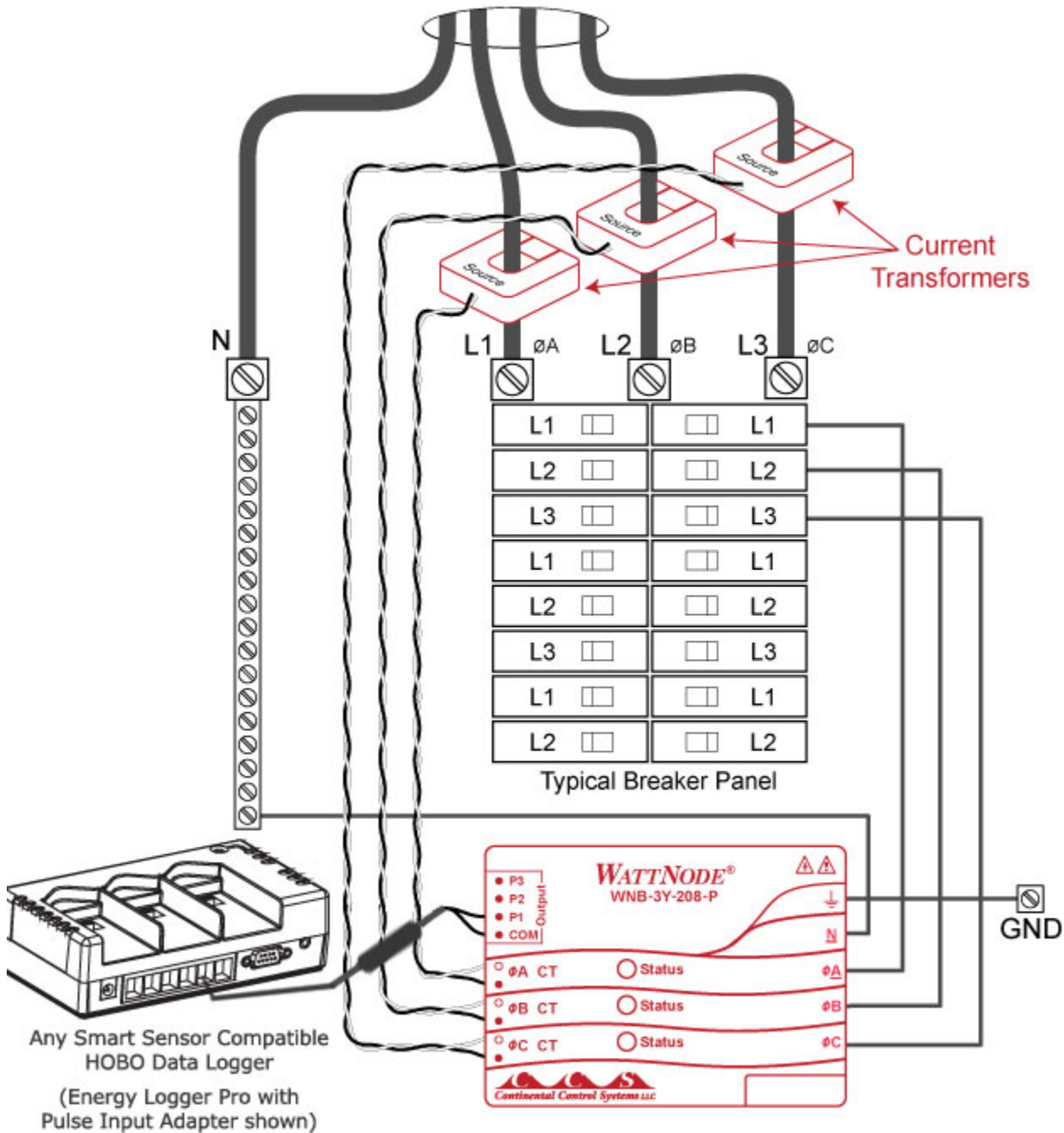

Delta or Wye configuration ranges: 480 Volts AC

3 Phase 3 Wire (No neutral)

3 Phase 4 Wire

Accuracy: $\pm 0.45\%$ of reading + 0.05% FS through 25th harmonic