

# HOBO® U30 Quick Start Guide

U30/GSM, U30/Wi-Fi

Follow the steps in this Quick Start Guide to configure a HOBO U30 Station with Remote Communication (GSM, Wi-Fi).

**NOTE:** This guide does not cover the following: configuration of the Analog Sensor Port or TRMS modules, configuring a static IP address (Wi-Fi only).

For more information see the *HOBO U30 Station/Remote Communication User Guide*, available as a printable file from the Onset web Site at: [www.onsetcomp.com/wi-fi](http://www.onsetcomp.com/wi-fi) or [www.onsetcomp.com/rms-outdoor](http://www.onsetcomp.com/rms-outdoor)

## Initial HOBOLink Setup

For more information on HOBOLink, see the *HOBOLink Help* available in the *HOBOLink* application at [hobolink.com](http://hobolink.com).

### Step 1 - Setup HOBOLink Account

If you have not already done so, set up a HOBOLink™ account. Go to <https://www.hobolink.com> and follow the instructions to create and activate a user account.

### Step 2 - Register the HOBO U30 Station

Click the *Register a Device* link and follow the instructions on the screen. Give the device a nickname, then enter both the serial number (SN) and Device Key (located on a label inside the HOBO U30 Station).

Click the name of the device to go to the **Device** window and configure the device.

### Step 3 - Change Time Zone (if necessary)

Click **Device Configuration** in the Task Bar.

### Step 4 - Configure the Logging Interval

- Click **Launch Configuration**.
- Enter a *Launch Description*. This will also be used as the filename for the data readouts.
- Select a *Logging Interval*. For an initial test, configure a fast logging interval.

### Step 5 - Configure the Connection Interval

- Click **Readout Configuration**.
- Enter a *Connection Interval* (how frequently the HOBO U30 Station will connect to HOBOLink). For an initial test, configure a fast *Connection Interval*.

**NOTE:** For the U30/GSM, the Connection Interval is limited by the Fastest Connection Allowed by your Communication Plan. For testing, you can bypass your GSM Communication Plan restrictions by manually connecting to HOBOLink using HOBOWare (direct connection using a USB cable). From the main menu select **Status**, and then click the **Contact HOBOLink** button.

Part# MAN-U30-RC Document # 12268-B

## Initial Hardware Setup

**IMPORTANT:** If you have a U30/Remote Communication model (GSM, Wi-Fi), your Communication Plan will be activated one week after the unit is shipped and you will begin paying for HOBOLink access, regardless of whether or not you have registered and activated your unit.

**IMPORTANT:** Always plug-in the battery first, before you plug-in any solar panel or power supply connector. When disconnecting power, always un-plug any solar panel or power supply connector first, then un-plug the battery.

### Step 1 - Install Mounting Plates

Screw the mounting plates onto the back of the HOBO U30 Station case using a Phillips-head screwdriver. Be careful to orient the plates so that the screw heads are sunk into the screw holes.

### Step 2 - Plug in Smart Sensors

Insert the Smart Sensor cables through the cable access opening in the bottom of HOBO U30 Station and plug them into the Smart Sensor jacks.

If you are using the Smart Sensor Expander Board, you should install cables in those slots first. You must first remove the Secondary Cable Slot cover. See the *U30 Station/Remote Communication User Guide* for details.

### Step 3 (Wi-Fi Only) - Connect the U30 to a Computer

Before you connect the battery, you must connect the U30/Wi-Fi Station to a computer using a USB cable supplied by Onset.

### Step 4 - Connect the Battery

Power up the HOBO U30 Station by plugging in the built-in battery cable into the battery connector.

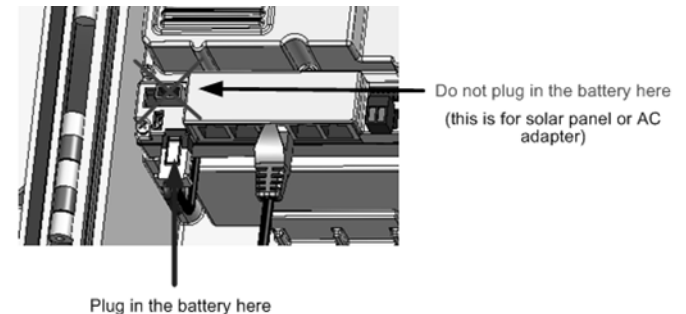

### Step 5 - Configure Analog Sensor Port or TRMS Module (Optional)

If you are using the Analog Sensor Port or TRMS modules, use HOBOWare now to perform that configuration. See the *HOBO U30 Station/Remote Communication User Guide* for details.

## Next Task

If you are setting up a U30/GSM Station, go to *Final HOBOLink Setup and Test*.  
If you are setting up a U30/Wi-Fi Station, go to *Configuring Wi-Fi Network Setup*.

## Configuring Wi-Fi Network Setup

**NOTE:** If you are not familiar with network configuration, consult with your Network Administrator or IT Department.

If you have a HOB0 U30/Wi-Fi Station, you must configure the network settings each time you move the HOB0 U30/Wi-Fi Station to a different network, using Onset's HOB0 Netsetup utility.

If your network uses static IP addresses rather than DHCP, you must configure a static IP Address. See the *HOB0 U30 Station/Remote Communication User Guide* for details.

**Step 1 - Download HOB0 NetSetup** (Supported for PC only)

**Before you Begin:** the HOB0 NetSetup utility requires Microsoft .NET Framework (version 2.0 or above) installed. To determine if you have this installed on your PC, go to **Start > Control Panel > Add or Remove Programs** and see if it is in the list of currently installed programs.

Onset's HOB0 Netsetup utility and Microsoft .NET Framework can be downloaded from the following location:  
[http://www.onsetcomp.com/support/software\\_utilities#downloads-1](http://www.onsetcomp.com/support/software_utilities#downloads-1)

**Step 2 - Launch HOB0 NetSetup.**

Default configuration information will scroll by as the program launches and then the welcome screen will appear.

**Step 3 - Click Begin.** The Change Setup screen appears:

**Step 4 - Access WLAN Setup**

**IMPORTANT: DO NOT select option 7 "save default values?"** The U30/Wi-Fi has been preconfigured by Onset Computer. Selecting option 7 from the setup menu will reset the unit to factory defaults, which will require extensive reconfiguration. Type *4* and press **Enter** to access the WLAN setup.

For a typical setup, you only need to enter the *Network Name*, the *Security Suite* and a *Device Key* or *Password*. You can accept the defaults for other parameters.

**Step 5 - Follow the prompts to configure WLAN.**

Default values are shown in parenthesis. To accept the default, hit **Enter**. For more information on options, see WLAN Options in the *HOB0 U30 Station/Remote Communication User Guide*.

**Step 6 - Save and Exit**

When finished, save the new configuration by typing *9* and pressing **Enter**.

"Parameters stored ...." will appear on the screen.

**Step 7 - Cycle power on the U30 Station** (disconnect and reconnect the battery)

The U30 Station will connect to HOBOLink at the next Connection Interval.

**Step 8 - Remove the USB cable from the U30 Station**

Go to *Final HOBOLink Setup and Test*.

## Final HOBOLink Setup and Test

**Step 1 - Log into HOBOLink**

**Step 2 - Perform additional HOBOLink configuration if required**  
(Label Sensors, Configure Alarms)

**NOTE:** If you wish to start a new launch once you set up the HOB0 U30 Station in the field, be sure to select *Force Relaunch on Next Connection* in **Launch Configuration**.

**Step 3 - Verify Proper Operation**

Make sure the data for all the Smart Sensors appears as expected in the Latest Conditions panel. Verify that graphs appear to be correct. Let the HOB0 U30 Station connect 2 or 3 times and verify the data after each connection.

**Step 4 - Configure Field Values**

When you are satisfied that the HOB0 U30 Station and HOBOLink are working properly, change your Logging Interval and Connection Interval to your desired settings for deployment.

**IMPORTANT:** For the U30/GSM, make sure your **Connection Interval** is set to the Average Connection Interval for your Communications Plan or slower.

**Step 5 - Repack the Logger and Sensors for Transit**

Onset strongly recommends that you use the original packaging when possible because it is custom-designed to protect the weather station and its components.

**Important:** If you are not deploying the system immediately, disconnect the battery to preserve battery power and reduce cellular transmission costs.

For instructions on *Installing the HOB0 U30 Station in the Field*, see the *HOB0 U30 Station/Remote Communication User Guide*.

---

### Support

For support, please contact the company that you bought the products from: Onset Computer Corporation or an Onset Authorized Dealer.  
1-800-LOGGERS (1-800-564-4377) or 508-759-9500  
8 AM to 5 PM ET, Monday through Friday Fax: 508-759-9100

### Contact Information

Onset Computer Corporation 470 MacArthur Blvd Bourne, MA 02532  
Mailing Address: PO Box 3450 Pocasset, MA 02559-3450  
email: [loggerhelp@onsetcomp.com](mailto:loggerhelp@onsetcomp.com) Main Onset website: [www.onsetcomp.com](http://www.onsetcomp.com)

© 2007-2008 Onset Computer Corporation.

All rights reserved. Onset, HOB0, HOB0ware, and HOBOLink are trademarks or registered trademarks of Onset Computer Corporation for its data logger products and configuration/interface software. All other trademarks are the property of their respective companies.