

Ashcroft® Pressure Transducer Connection Instructions for use with HOBO® H22 and U30 Series Data Loggers

Applies to these Ashcroft Pressure Transducers:

Onset Part No.	Rating	Output	Ashcroft Part No.
T-ASH-G2-100	100 PSIG	0-5V representing 0 to 100 PSIG	G27M0205F2100#G-#4177
T-ASH-G2-200	200 PSIG	0-5V representing 0 to 200 PSIG	G27M0205F2200#G-#4177
T-ASH-G2-500	500 PSIG	0-5V representing 0 to 500 PSIG	G27M0205F2500#G-#4177

This document provides instructions on connecting the Ashcroft Pressure Transducers listed above to either the FlexSmart™ Analog Module used with HOBO H22 series data loggers or to the Analog Sensor Port option used with HOBO U30 series loggers. It also lists configuration values used by HOBOWare® Pro software to configure the logger for each transducer. **Note:** For information on connecting the pressure transducer to the pressure source, and other transducer details, refer to the documentation provided by Ashcroft.



Ashcroft Pressure Transducer

Required:

- Selected Ashcroft Pressure Transducer
- HOBO H22 or U30 Series Data Logger
- FlexSmart Analog Module, Onset Part No: S-FS-CVIA (for H22 series) or Analog Sensor Port option (for U30 series)
- HOBOWare Pro Software, version 2.2.1 or higher (2.4.0 or higher for U30 series)

Connecting the Pressure Transducer to the Analog Module or Port:

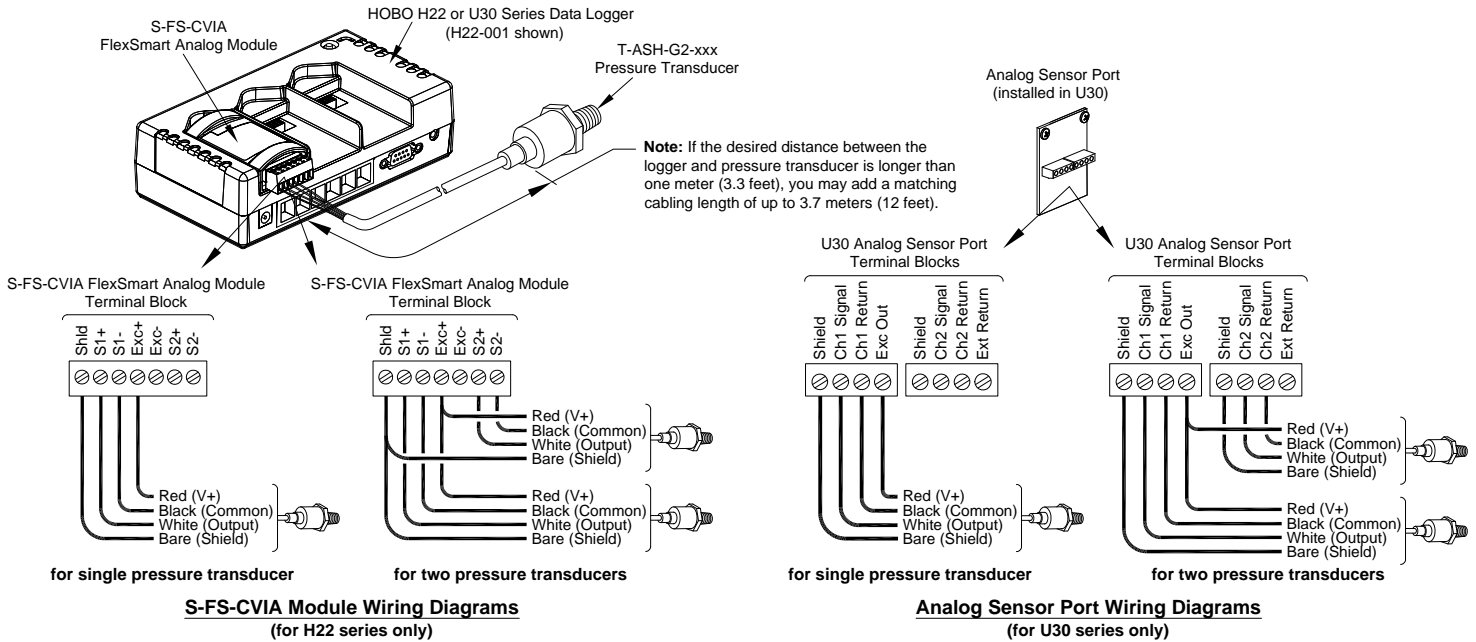

Configuring the Data Logger for the Pressure Transducer, using HOBOWare Pro Software:

Note: HOBOWare Pro software provides configuration files for the transducers. The table below lists the recommended configuration values for each transducer that these files contain. For information on loading configuration files, refer to the software documentation.

Onset Part No.	Channel Name	Warm-Up*	Measurement Type	Raw Value 1	Raw Value 2	Raw Units	Scaled Value 1	Scaled Value 2	Scaled Units
T-ASH-G2-100	Pressure	0.03 sec	Voltage	0	5	V	0	100	PSIG
T-ASH-G2-200	Pressure	0.03 sec	Voltage	0	5	V	0	200	PSIG
T-ASH-G2-500	Pressure	0.03 sec	Voltage	0	5	V	0	500	PSIG

*Warm-up excitation power provided by the FlexSmart Analog Module and H22 (or Analog Sensor Port and U30).

Service and Support

HOBO products are easy to use and reliable. In the unlikely event that you have a problem with this instrument, contact the company where you bought the logger: Onset or an Onset Authorized Dealer. Before calling, you can evaluate and often solve the problem if you write down the events that led to the problem (are you doing anything differently?) and if you visit the Technical Support section of the Onset web site at www.onsetcomp.com/support.html. When contacting Onset, ask for technical support and be prepared to provide the product number and serial number for the logger and software version in question. Also completely describe the problem or question. The more information you provide, the faster and more accurately we will be able to respond.

Onset Computer Corporation
470 MacArthur Blvd., Bourne, MA 02532
Mailing: PO Box 3450, Pocasset, MA 02559-3450
Phone: 1-800-LOGGERS (1-800-564-4377) or 508-759-9500
Fax: 508-759-9100
E-mail: loggerhelp@onsetcomp.com
Internet: www.onsetcomp.com

Warranty

Onset Computer Corporation (Onset) is acting as a distributor of the sensor(s) or transducer(s) described in this document. Onset hereby transfers to the original end-user purchaser the warranty provided by the product manufacturer (**one year** from the date of original purchase). During the warranty period Onset will, at its option, either repair or replace products that prove to be defective in material or workmanship. This warranty shall terminate and be of no further effect at the time the product is (1) damaged by extraneous cause such as fire, water, lightning, etc. or not maintained in accordance with the accompanying documentation; (2) modified; (3) improperly installed; (4) repaired by someone other than Onset; or (5) used in a manner or purpose for which the product was not intended.

THERE ARE NO WARRANTIES BEYOND THE EXPRESSED WARRANTY ABOVE. IN NO EVENT SHALL ONSET BE LIABLE FOR LOSS OF PROFITS OR INDIRECT, CONSEQUENTIAL, INCIDENTAL, SPECIAL OR OTHER SIMILAR DAMAGES ARISING OUT OF ANY BREACH OF THIS CONTRACT OR OBLIGATIONS UNDER THIS CONTRACT, INCLUDING BREACH OF WARRANTY, NEGLIGENCE, STRICT LIABILITY, OR ANY OTHER LEGAL THEORY.

Limitation of Liability. The Purchaser's sole remedy and the limit of Onset's liability for any loss whatsoever shall not exceed the Purchaser's price of the product(s). The determination of suitability of products to the specific needs of the Purchaser is solely the Purchaser's responsibility. **THERE ARE NO WARRANTIES BEYOND THE EXPRESSED WARRANTY OFFERED WITH THIS PRODUCT. EXCEPT AS SPECIFICALLY PROVIDED IN THIS DOCUMENT, THERE ARE NO OTHER WARRANTIES EXPRESS OR IMPLIED, INCLUDING BUT NOT LIMITED TO, ANY IMPLIED WARRANTIES OF MERCHANTABILITY OR FITNESS FOR A PARTICULAR PURPOSE. NO INFORMATION OR ADVICE GIVEN BY ONSET, ITS AGENTS OR EMPLOYEES SHALL CREATE A WARRANTY OR IN ANY WAY INCREASE THE SCOPE OF THE EXPRESSED WARRANTY OFFERED WITH THIS PRODUCT.**

Indemnification. Products supplied by Onset are not designed, intended, or authorized for use as components intended for surgical implant or ingestion into the body or other applications involving life-support, or for any application in which the failure of the Onset-supplied product could create or contribute to a situation where personal injury or death may occur. Products supplied by Onset are not designed, intended, or authorized for use in or with any nuclear installation or activity. Products supplied by Onset are not designed, intended, or authorized for use in any aeronautical or related application. Should any Onset-supplied product or equipment be used in any application involving surgical implant or ingestion, life-support, or where failure of the product could lead to personal injury or death, or should any Onset-supplied product or equipment be used in or with any nuclear installation or activity, or in or with any aeronautical or related application or activity, Purchaser will indemnify Onset and hold Onset harmless from any liability or damage whatsoever arising out of the use of the product and/or equipment in such manner.

Returns

Please direct all warranty claims and repair requests to place of purchase.

Before returning a failed unit directly to Onset, you must obtain a Return Merchandise Authorization (RMA) number from Onset. You must provide proof that you purchased the Onset product(s) directly from Onset (purchase order number or Onset invoice number). Onset will issue an RMA number that is valid for 30 days. You must ship the product(s), properly packaged against further damage, to Onset (at your expense) with the RMA number marked clearly on the outside of the package. Onset is not responsible for any package that is returned without a valid RMA number or for the loss of the package by any shipping company. Loggers must be clean before they are sent back to Onset or they may be returned to you.

Repair Policy

Products that are returned after the warranty period or are damaged by the customer as specified in the warranty provisions can be returned to Onset with a valid RMA number for evaluation.

© 2005 – 2008 Onset Computer Corporation. All rights reserved.

Manual Part No: MAN-ASHCROFT

Doc No: 10274-D

Onset, HOBO, and HOBOWare are registered trademarks and FlexSmart is a trademark of Onset Computer Corporation. Other products and brand names may be trademarks or registered trademarks of their respective owners.